

CABINET UNIT HEATERS



STEAM AND HOT WATER
CABINET UNIT HEATERS



Vulcan
RADIATOR

CABINET UNIT HEATERS

**SELECTION AND "ROUGH IN" MADE EASY -
ONLY THE LENGTHS VARY**



The Vulcan Cabinet Unit Heater is the industry's most recent design. Years of manufacturing and engineering experience combined with a concern for appearance have resulted in a crisply styled unit that will blend with almost any room decor and provide reliability, durability, individual control and quiet operation.

As unit size increases, only the length changes. The depth and height remain constant, thus allowing the designer to have uniformity of appearance when units of various sizes are installed in adjacent areas.

The wide selection of floor, wall and ceiling units with a variety of air flow arrangements allows for exactly matching design requirements.

The standard 16-gauge front panel is rugged enough to withstand harsh treatment. Exposed cabinetry is provided with a neutral eggshell baked powder finish. Back and side panels are 18-gauge.

The pedestal base for floor models is the height of most mop boards.

Field repainting to match the decor is possible and factory applied decorator colors are available as an option.

Recessed models are provided with a field installed wall seal that allows for full or partial recessing depending on the model. The wall seal kit is also available as an option for full or partial recessing of most other models.

The solid state speed control provides infinite variations from high to low speed, giving the occupant finger tip control over fan speed and room temperature.

All Vulcan commercial hydronic products are made from recycled materials. Recycled material contents can be obtained from your local Vulcan representative.

All units are CSA certified.



10 MODELS - 28 ARRANGEMENTS - 8 CFM SIZES



F

FLOOR TYPE



FI

FLOOR TYPE, INVERTED FLOW



FS

FLOOR TYPE SLOPE TOP



FSI

FLOOR TYPE SLOPE TOP, INVERTED FLOW



**W
&
WI**

WALL TYPE and INVERTED FLOW



**RW
&
RWI**

RECESSED WALL and INVERTED FLOW



C

CEILING MOUNTED



RC

RECESSED CEILING MOUNTED

See page 6 for arrangements.

CABINET UNIT HEATER STANDARD FEATURES

- Adjustable wall seal to suit recessing requirements.

- Copper Aluminum coil for steam or hot water.

- Support bracket to wall.

- Whisper quiet blowers.

- Cabinet finish neutral eggshell baked powder.

- Leveling legs optional.

- 16-Gauge steel front panel with insulation, standard.

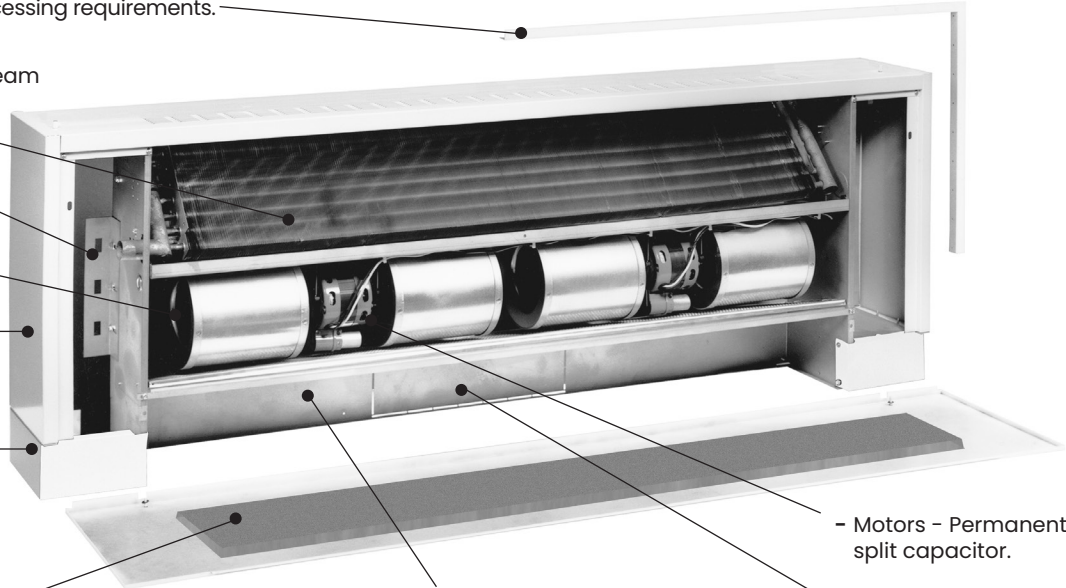

- Motors - Permanent split capacitor.

- Permanent washable filter, aluminum fiber media.

- Outside air knockout provided standard on "F" and "FS" models.



- Speed Control / Access doors - Standard on all floor and wall models. (Speed switch shipped loose on ceiling models.)

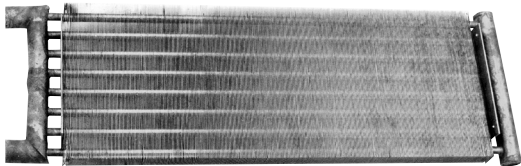

- Steam Coil (Standard) - Brazed copper tube and header with aluminum fin. Factory tested to 250 PSI.



- Access Area typical both ends.



- Optional High Capacity 2 row coil.

WALL SEAL – The optional wall seal kit with gasket is designed to allow for easy installation and permanent protection for the wall board, plaster or sheet rock surrounding the unit on recessed models.

COILS –

STANDARD ONE ROW – The durable mechanically bonded copper/aluminum coil presents the best of today's hydronic technology. Providing 12 fins per inch with 1/2" nominal diameter tubes, the ultimate in BTU capacity is provided without sacrificing noise, vibration or amp draw. All element assemblies are submersion tested at factory at 250 PSI and are rated at a working pressure of 300 PSI. All units are designed so that field modifications can be made to reverse the coil position if required.

HIGH CAPACITY COIL – This is a hot water coil designed to provide increased capacity when the required load exceeds that of the standard coil for a given size. Its construction is similar to the standard coil; however, fins are double depth and there are two rows of tubes. Element assemblies are submersion tested at 250 PSI and are rated at a working pressure of 300 PSI.

BLOWER FAN ASSEMBLY – The blower fan assembly provides one of the industry's best CFM output per unit size. The sizes range from 200 CFM up to the 1400 CFM unit at 115 volts. This is the widest range of sizes in the industry.

MOTORS – Standard motors are (PSC) permanent split capacitor. This provides the ultimate in motor life, operating cost, noise levels and dependability. A standard shaft size of 1/2" diameter is the same on all motors. By using a solid state variable speed switch, a range of speeds can be achieved. Motors are either 1/15 or 1/10 HP.

ECM MOTOR – Optional motors are Electronically Commutated Motors (ECM). These motors are highly efficient at full and part load with efficiencies up to 85% compared to 40% with traditional PSC motors. The ECM motors are also 1/15 or 1/10 HP with low power consumption, providing energy savings which will satisfy green building initiatives.

FILTER – The standard permanent filter is made of durable aluminum which has an average arrestance of 69%. Light and easy to handle, the filter slides into its locating channel and is permanently held in position with factory supplied cotter pins.

FRONT PANEL – 16-gauge front panel is standard with 1/2" - 1-1/2 lb. density, neoprene one side insulation in front of the coil. Full panel insulation is available as an option. Tamper resistant fasteners are also available.

MOTOR/BLOWER SHELF – Support shelf adds support to units strength and structural integrity. A support gusset is supplied with 600 CFM units and up.

FINISH – Standard finish is an aesthetically pleasing neutral eggshell baked powder, which is suitable for field repainting if necessary. Optional colors available as shown on color chart.

LEVELING LEG – Optional leveling legs are available. Four (4) legs per unit allow adjustment for pitch and yaw when unit is mounted on uneven floors.

SPEED CONTROL / ACCESS DOOR – The solid state speed control allows infinite speed selection for comfort control. Located under the finger touch access door, the speed control is out of view yet easily accessible. The access door requires just the pressure of a finger to open and swings 120° to a stay open position. The access door comes with a standard 1/4 turn/philips head fastener and is available with optional tamper resistant fastener. Speed control switch is not mounted on C or RC units.

ACCESS AREA – A spacious rough-in area is provided between the unit ends and the internal cabinet at both ends. The removable front panel allows full access to the piping and valve area (left-hand standard) and to the wiring, switch area. Right hand shown. The rear portion is enclosed with sheet metal.

HINGED PANEL / CEILING UNIT – The hinged panels on all ceiling units are standard. Stop chains are standard. Speed control switches are shipped inside unit with wiring diagram. Switch can be mounted internal or remote from unit.

CONSTANT CABINET DIMENSIONS – Throughout the design of the cabinet unit heater, one feature has been a primary concern – "uniformity." The cabinet depth is one dimension on all unit sizes. Along with that, the cabinet height is constant on all units except FS and FSI. Only the length changes on these models. The internal cabinet allows for all controls and piping to be reversible by making all locator and fastener holes in mirror image.

SLOPING TOP CABINETS – Best feature for areas that cannot tolerate accumulations of books, cups, paper, etc.

CABINET UNIT HEATERS

MODELS AND AIRFLOW ARRANGEMENTS

MODEL			ARRANGEMENT NUMBER				
Floor	F		F-1000	F-1010 25% F.A.	F-1020 ← See options 18 & 19 →	F-1030 25% F.A.	
Floor Inverted Flow	FI		FI-1040	FI-1050			
Slope	FS		FS-1005	FS-1015 25% F.A.	FS-1025 ← See options 18 & 19 →	FS-1035 25% F.A.	
Slope Inverted Flow	FSI		FSI-1045	FSI-1055			
Wall	W		W-1060	W-1070	W-1080		
Wall Inverted Flow	WI		WI-1090	WI-1100	WI-1110		
Recessed Wall	RW		RW-1120		RWI-1130		
Recessed Wall Inverted Flow	RWI						
Ceiling	C		C-1140	C-1150	C-1160	C-1170	C-1180
Recessed Ceiling	RC		RC-1190	RC-1200	RC-1210		

CAT00207

MODELS, ARRANGEMENTS AND SIZES ARE DESIGNATED AS FOLLOWS:

EXAMPLE - RC - 1190 - 08

MODEL ARRANGEMENT SIZE

SIZE	02	03	04	06	08	10	12	14
CFM	230	335	430	630	860	1060	1230	1410

CABINET UNIT HEATERS

RATINGS AND SPECIFICATIONS

ENTERING WATER - 200°F
ENTERING AIR - 60°F

TABLE 1

UNIT SIZE		02	03	04	06	08	10	12	14
Heating Cap. - Hot Water	MBH	16.4	22.8	29.8	48.0	54.5	62.0	75.6	78.5
	20 WTD GPM	1.64	2.28	2.98	4.80	5.46	6.20	7.56	7.85
High Cap. - Coil 2 Row Heating Cap. Hot Water	MBH	25.8	35.4	46.3	69.8	87.6	101.8	119.8	128.6
	20 WTD GPM	2.58	3.54	4.63	6.98	8.76	10.18	11.98	12.86
Heating Cap. - Steam 2 PSIG Standard Coil	MBH	22.6	31.4	41.0	66.1	75.1	85.4	104.1	108.2
	EDR	94	131	171	276	313	356	434	451
	Cond. LB/HR	23.4	32.5	42.4	68.4	77.7	88.4	107.7	112
Coil:	Number Fins Per Inch	12	12	12	12	12	12	12	12
	Face Area-Ft. ²	.97	1.5	1.8	2.6	2.8	3.1	3.6	4.4
	Coil Connections	1-1/4CU	1-1/4CU	1-1/4CU	1-1/4CU	1-1/4CU	1-1/4CU	1-1/4CU	1-1/4CU
Blowers:	Number	1	1	2	2	3	3	4	4
Standard PSC Motor:	HP	1/15	1/15	1/10	1/10	1 @ 1/10 1 @ 1/15	1 @ 1/10 1 @ 1/15	1/10	1/10
	RPM: High	1050	1050	1050	1050	1050	1050	1050	1050
	Low	875	875	875	875	875	875	875	875
	Number	1	1	1	1	2	2	2	2
	Volts/Phase/Hertz	115/1/60	115/1/60	115/1/60	115/1/60	115/1/60	115/1/60	115/1/60	115/1/60
Fan Speed Control	Amperes	0.8	0.8	1.4	1.4	2.2	2.2	2.8	2.8
	Standard Mtr	VAR.	VAR.	VAR.	VAR.	VAR.	VAR.	VAR.	VAR.
	CFM: High	230	335	430	630	860	1060	1230	1410
Optional ECM Motor:	Low	185	270	345	505	685	845	985	1130
	HP	1/15	1/15	1/15	1/15	1/10	1/10	1/4	1/4
	Number	1	1	1	1	2	2	2	2
	Volts/Phase/Hertz	120/1/60	120/1/60	120/1/60	120/1/60	120/1/60	120/1/60	120/1/60	120/1/60
	Amperes	0.45	0.45	0.65	0.85	1.5	1.95	2.8	2.8
Fan Speed Control	ECM	3 - SPEED	3 - SPEED	3 - SPEED	3 - SPEED	3 - SPEED	3 - SPEED	3 - SPEED	3 - SPEED
	CFM: High	230	335	430	630	860	1060	1230	1410
	Med	160	240	375	440	590	740	850	980
	Low	120	150	280	320	450	560	640	730
Filter:	No.	1	1	1	1	1	1	1	1
	Type	PERM.	PERM.	PERM.	PERM.	PERM.	PERM.	PERM.	PERM.
	Length (in)	19-3/4	27-3/4	31-3/4	43-3/4	45-3/4	50-3/4	57-3/4	69-3/4
	Width (in)	8-11/16	8-11/16	8-11/16	8-11/16	8-11/16	8-11/16	8-11/16	8-11/16
	Thickness (in)	1/2	1/2	1/2	1/2	1/2	1/2	1/2	1/2
dB. Level 18" From Unit		50	52	53	54	55	55	56	56
	Length (in)	35	43	47	59	61	66	73	85
	Height (in)	25	25	25	25	25	25	25	25
	Depth (in)	9-1/2	9-1/2	9-1/2	9-1/2	9-1/2	9-1/2	9-1/2	9-1/2

CABINET UNIT HEATERS

SHIPPING WEIGHT (LBS)

STYLE	SIZE							
	02	03	04	06	08	10	12	14
F-FI	92	109	122	148	166	176	196	221
FS-FSI	94	111	124	150	168	178	198	223
W-WI-RW-C	97	115	128	157	175	185	207	234
RC	102	121	135	164	183	194	215	243

CABINET UNIT HEATERS

HEATING CAPACITIES

TABLE 2 — STANDARD COIL

ENTERING WATER – 200°F
ENTERING AIR – 60°F

UNIT SIZE	GPM	WATER PD/FT	HIGH FAN SPEED				LOW FAN SPEED			
			CFM	MBH	WTD	FAT	CFM	MBH	WTD	FAT
02	.84	.06	230	14.3	34.0	117	185	12.9	30.6	124
	1.0	.06		15.1	30.2	120		13.8	27.6	129
	1.5	.15		16.2	21.6	125		15.0	20.0	135
	2.0	.24		17.4	17.4	130		16.1	16.1	140
	2.5	.36		18.8	15.0	135		17.3	13.8	146
03	1.0	.07	335	21.3	42.6	118	270	19.1	38.2	125
	1.5	.16		22.0	26.6	120		19.8	26.4	128
	2.0	.26		22.7	22.7	122		20.1	20.1	129
	2.5	.39		23.5	18.8	125		20.7	16.6	131
	3.0	.55		23.8	15.8	126		21.1	14.1	132
04	1.0	.07	430	21.8	43.6	106	345	19.0	38.0	111
	2.0	.27		26.6	26.6	117		23.9	23.9	124
	2.5	.41		29.0	23.2	122		25.8	20.5	129
	4.0	1.00		30.9	15.4	126		27.4	13.7	133
	5.0	1.45		32.3	12.9	129		28.3	11.3	136
06	2.0	.30	630	40.4	40.4	119	505	35.7	35.7	125
	3.0	.63		44.8	29.8	125		39.8	26.5	133
	4.0	1.10		47.2	23.6	129		41.9	21.0	136
	5.0	1.60		49.4	19.8	132		43.6	17.5	140
	6.0	2.25		50.7	16.9	134		44.6	15.0	142
08	2.0	.31	860	47.1	47.1	110	685	42.0	42.0	117
	3.0	.64		52.2	34.8	115		46.5	31.0	123
	4.0	1.10		53.9	26.9	117		48.3	24.2	125
	6.0	2.25		56.0	18.6	120		49.1	16.4	126
	8.0	3.85		57.8	14.4	122		51.2	12.8	129
10	3.0	.65	1060	55.8	32.7	109	845	50.2	33.5	115
	4.0	1.15		60.4	30.2	112		53.5	26.8	118
	6.0	2.35		62.2	20.7	114		54.7	18.2	120
	8.0	4.00		64.1	16.0	116		56.3	14.1	121
	10.0	6.00		66.0	13.2	117		58.9	11.8	124
12	4.0	1.20	1230	71.5	35.7	113	985	65.1	32.6	131
	6.0	2.50		74.5	24.8	116		66.6	22.2	133
	8.0	4.20		76.7	19.1	117		68.0	17.0	134
	10.0	6.30		77.7	15.5	118		69.0	13.8	135
	12.0	8.85		78.6	13.1	119		69.7	11.6	136
14	3.5	1.00	1410	71.0	40.6	106	1130	66.3	37.9	114
	4.0	1.30		74.1	37.0	108		68.4	34.2	116
	6.0	2.70		77.6	25.9	111		69.9	23.3	117
	10.0	6.80		80.9	16.2	113		72.5	14.5	119
	12.0	9.55		81.7	13.6	113		73.0	12.2	120

CABINET UNIT HEATERS

HEATING CAPACITIES

TABLE 3 — HIGH CAPACITY — 2 ROW COIL

ENTERING WATER - 200°F
ENTERING AIR - 60°F

UNIT SIZE	GPM	WATER PD/FT	HIGH FAN SPEED				LOW FAN SPEED			
			CFM	MBH	WTD	FAT	CFM	MBH	WTD	FAT
02	1.68	.26	225	23.6	27.9	157	180	21.2	25.3	169
	2.0	.34		24.8	24.8	162		22.5	22.5	175
	2.5	.50		25.7	20.6	165		23.5	18.8	180
	3.0	.73		26.6	18.1	169		23.9	16.0	183
	3.5	.96		27.5	15.9	173		24.8	14.1	187
03	1.68	.27	330	30.3	36.0	149	265	27.3	32.5	155
	2.0	.38		33.1	33.1	152		29.7	29.7	163
	2.5	.56		34.3	27.4	156		30.3	24.2	165
	3.0	.77		34.9	23.3	157		30.8	20.5	167
	3.5	.96		35.3	20.2	159		31.8	18.2	170
04	1.68	.30	420	37.2	43.6	142	335	33.5	39.9	152
	2.0	.44		39.5	39.5	147		35.8	35.8	158
	2.5	.59		42.4	33.9	153		37.8	30.2	164
	4.0	1.41		45.4	22.7	160		39.7	19.9	169
	5.0	2.04		46.8	18.7	163		40.8	16.3	172
06	2.0	.45	620	57.6	57.6	146	495	52.7	52.7	158
	3.0	.93		63.1	42.1	154		57.0	38.0	166
	4.0	1.60		66.0	33.0	158		59.7	29.9	171
	5.0	2.30		69.1	27.6	163		61.2	24.5	174
	6.0	3.30		69.5	23.2	164		62.0	20.7	175
08	2.0	.46	845	67.1	67.1	133	675	58.1	58.1	139
	3.0	.95		75.8	50.5	143		68.2	45.5	153
	4.0	1.65		79.3	39.7	146		71.6	35.8	158
	6.0	3.35		82.6	27.5	150		73.4	24.5	160
	8.0	5.60		86.5	21.6	154		75.8	19.0	163
10	3.0	1.00	1040	84.6	56.4	135	830	75.9	50.6	144
	4.0	1.75		90.6	45.3	140		81.2	40.6	150
	6.0	3.50		94.6	31.5	144		84.0	28.0	153
	8.0	5.90		98.6	24.7	147		86.3	21.6	156
	10.0	8.85		101.6	20.3	150		88.9	17.8	159
12	4.0	1.85	1210	105.3	52.7	140	970	93.3	46.7	149
	6.0	3.75		111.6	37.2	145		100.4	33.5	155
	8.0	6.30		115.3	28.8	148		102.8	25.7	158
	10.0	9.45		118.1	23.6	150		105.0	21.0	160
	12.0	13.20		119.8	20.0	151		106.7	17.8	161
14	4.0	2.05	1385	109.8	54.9	133	1110	100.2	50.1	143
	5.0	3.00		114.8	45.9	136		103.5	41.4	146
	6.0	4.15		118.3	39.4	139		106.6	35.5	149
	10.0	10.45		125.8	25.2	144		111.4	22.3	152
	12.0	14.55		127.9	21.3	145		112.2	18.7	153

SELECTION

SELECTION PROCEDURE

1. Determine job requirements
 - a. Type of heating (steam or hot water).
 - b. Minimum heating capacity (BTU/HR or EDR).
2. Select unit size
 - a. If necessary convert the required BTU/hr to rated conditions as specified in the capacity tables. (Refer to the formulas at right).
 - b. Select unit(s) from tables with capacities equal to or slightly higher than the BTU/HR required. Read directly the motor HP and fan RPM.

$$\text{Formulas: BTU/HR at rated conditions} = \frac{\text{BTU/HR at required conditions}}{\text{CONVERSION FACTOR}}$$

$$\text{FT (Final Air Temperature)} =$$

$$\text{Entering Air Temp.}^\circ\text{F} + \frac{\text{BTU/HR}}{\text{CFM} \times 1.085}$$

$$\text{GPM (Gallons Per Minute)} = \frac{\text{BTU/HR}}{\text{Water Temperature Drop} \times 500}$$

HOT WATER COIL CAPACITY

EXAMPLE:

Heating load 34,000 BTUH
 Entering air temp 60°F
 Entering water temp 140°F
 Water temp drop 30°F

From Table 7, page 12
 Correction Factor .571
 for 140°F entering water temp

From Table 8, page 12
 Capacity Correction Factor .90
 for 30°F water temp drop

$$\text{Equivalent Standard Capacity} = \frac{34,000}{(.571 \times .90)} = 66,160 \text{ BTUH}$$

Table 1 on page 7 shows selection of size 06 (2 row coil) with 69,800 BTU at 20°F water temp drop, sufficient for application.

Capacity at 20°F water temp drop with 140°F entering water = 69,800 x .571 = 39,856 BTUH

$$\text{Water Flow at 20°F water temp drop with 140°F entering water} = \frac{39,856}{(500 \times 20)} = 3.99 \text{ GPM}$$

FINAL CALCULATIONS:

Actual capacity at water drop temp with 140°F entering water = 39,856 x 0.9 = 35,870 BTUH

From Table 8, page 12
 Water Flow Correction Factor .59
 for 30°F water temp drop

Water Flow at 30°F water temp drop with 140°F entering water = 3.99 x .59 = 2.35 GPM

Table 3 on page 9 shows 620 CFM for high speed fan setting

$$\text{Final air temp} = \frac{35,870}{(620 \times 1.085)} + 60^\circ\text{F} = 113^\circ\text{F}$$

STEAM COIL CAPACITY

EXAMPLE:

Heating Load 34,000 BTUH
 Entering Air Temp 60°F
 Entering Steam Pressure 10 psig

From Table 5 Page 11
 correction is 1.13 for 10 psig.

$$\text{Equivalent Capacity} = \frac{34,000}{1.13} = 30,088 \text{ BTUH}$$

Table 1 on Page 7 shows selection of size 03 with 31,400 BTUH is sufficient for application.

$$\text{Actual Capacity} = 31,400 \times 1.13 = 35,482 \text{ BTUH}$$

$$\text{Condensate Rate} = \frac{\text{Actual Capacity}}{\text{Latent Heat of Steam}}$$

$$+ \frac{35,482}{953} = 37 \text{ lbs/hr}$$

$$\text{Final Air Temp} = \frac{35,482}{335 \times 1.085} + 60^\circ\text{F} = 157^\circ\text{F}$$

STATIC PRESSURE CORRECTION FACTORS FOR BTU OUTPUT/WITH STANDARD MOTOR

EXAMPLE: Unit - C-1150-08 output at 200°/60°F = 56 MBH at 6 GPM. Static Pressure = .125, Correction factor = .79 56,000 x .79 = 44,240 BTU corrected.

NOTE: High Static Motor Options 20 and 51 maintain standard air flow with external static pressure up to 0.4" water column.

TABLE 4

UNIT SIZE	0.0 ESP		0.05 ESP		0.1 ESP		0.125 ESP	
	CFM	BTU FACTOR	CFM	BTU FACTOR	CFM	BTU FACTOR	CFM	BTU FACTOR
02	230	1.00	205	.92	165	.82	145	.79
03	335	1.00	290	.92	240	.82	210	.79
04	430	1.00	390	.92	315	.82	275	.79
06	630	1.00	560	.92	450	.82	400	.79
08	860	1.00	750	.92	620	.82	540	.79
10	1060	1.00	925	.92	755	.82	660	.79
12	1230	1.00	1060	.92	865	.82	750	.79
14	1410	1.00	1210	.92	980	.82	850	.79

STEAM CALCULATIONS AND CORRECTION FACTORS

I. CAPACITY A. For 2 lbs steam, 60°F entering air temp.	Read output directly from Table 1 on page 7.
B. For higher steam pressures and or EAT's above or below 60°F	Multiply output from Table 1 on page 7 by appropriate correction factor from Table 5 (below).
II. FINAL AIR TEMPERATURE A. For 2 lbs steam, 60°F entering air temp.	See Table 1 on page 7 for Steam MBH Capacity. See page 10 for Steam Coil Capacity example.
B. For capacities calculated in IB (above)	$\frac{\text{Output from IB (above)}}{1.085 \times \text{CFM from Table 1 page 7}} + \text{EAT} = \text{Final Air Temp.}$
III. CONDENSATE PER HOUR A. For 2 lbs steam, 60°F entering air temp.	Read lbs per hour from Table 1 on page 7.
B. For capacities calculated in IB (above)	$\frac{\text{Output from IB (above)}}{\text{Latent Heat from Table 6}} = \text{lbs per hour of condensate}$

TABLE 5 — STEAM CORRECTION FACTORS BASED ON 2 LBS STEAM 60°F EAT

ENTERING AIR TEMPERATURE	STEAM PRESSURE — POUNDS PER SQUARE INCH (SATURATED)								
	0	2	5	10	15	20	30	40	50
30°F	1.19	1.24	1.29	1.38	1.44	1.50	1.60	1.68	1.76
40°F	1.11	1.16	1.21	1.29	1.34	1.42	1.51	1.60	1.67
50°F	1.03	1.08	1.13	1.21	1.28	1.33	1.43	1.51	1.58
60°F	0.96	1.00	1.05	1.13	1.19	1.25	1.35	1.43	1.50
70°F	0.88	0.93	0.97	1.06	1.12	1.17	1.27	1.35	1.42
80°F	0.81	0.85	0.90	0.98	1.04	1.10	1.19	1.27	1.34
90°F	0.74	0.78	0.83	0.91	0.97	1.02	1.12	1.19	1.26
100°F	0.67	0.71	0.76	0.84	0.90	0.95	1.04	1.12	1.19

TABLE 6 — PROPERTIES OF SATURATED STEAM

	STEAM PRESSURE IN POUNDS PER SQUARE INCH GAUGE								
	0	2	5	10	15	20	30	40	50
Steam Temperature-°F	212.0	218.5	227.1	239.4	249.8	258.8	274.0	286.7	297.7
Latent Heat of Steam	970	966	961	953	946	940	929	920	912

HOT WATER CALCULATIONS AND CORRECTION FACTORS

I. CAPACITY @ 20°F TD: A. For 200°F EWT, 60°F EAT	Read output directly from Table 1 on page 7.
B. For EWT and/or EAT above or below Standard	Multiply output from Table 1 on page 7 by factor from Table 7 (below).
II. CAPACITY AT OTHER TD'S A. For TD's from 5 to 60°F	Multiply output obtained in IA or IB (above) by appropriate factor from Table 8 (below).
III. GPM AT OTHER TD'S A. For TD's from 5 to 60°F	Multiply GPM of unit for 20°F TD by factor from Table 7 (below) EWT/EAT Then multiply by appropriate factor from Table 8 (below).
IV. PRESSURE LOSS AT OTHER TD'S A. For TD's from 5 to 60°F	Multiply PD of unit for 20°F TD by appropriate factor from Table 8 (below).

TABLE 7 — HOT WATER CONVERSION FACTORS BASED ON 200°F ENTERING WATER 60°F ENTERING AIR 20°F TEMPERATURE DROP

ENTERING AIR TEMPERATURE	ENTERING WATER TEMPERATURE — 20°F WATER TEMPERATURE DROP										
	100°F	120°F	140°F	160°F	180°F	200°F	220°F	240°F	260°F	280°F	300°F
30°F	0.518	0.666	0.814	0.963	1.120	1.260	1.408	1.555	1.702	1.850	1.997
40°F	0.439	0.585	0.731	0.878	1.025	1.172	1.317	1.464	1.609	1.755	1.908
50°F	0.361	0.506	0.651	0.796	0.941	1.085	1.231	1.375	1.518	1.663	1.824
60°F	0.286	0.429	0.571	0.715	0.857	1.000	1.143	1.286	1.429	1.571	1.717
70°F	0.212	0.353	0.494	0.636	0.777	0.918	1.060	1.201	1.342	1.483	1.63
80°F	0.140	0.279	0.419	0.558	0.698	0.837	0.977	1.117	1.257	1.397	1.545
90°F	0.069	0.207	0.345	0.483	0.621	0.759	0.897	1.035	1.173	1.311	1.462
100°F	0.000	0.137	0.273	0.409	0.546	0.682	0.818	0.955	1.094	1.230	1.371

To obtain the BTU capacity for conditions other than those in the basic capacity tables, multiply the basic rating (200°F when entering water, 60°F entering air,) by the proper constant from the above tables.

TABLE 8 — HOT WATER BTU, GPM AND PRESSURE LOSS FACTORS BASED ON STANDARD CONDITIONS OF 200°F ENTERING WATER 60°F ENTERING AIR AND 20°F WATER DROP

USE FACTORS FROM THIS TABLE TO OBTAIN APPROXIMATE RESULTS	TEMPERATURE DROP°F									
	5	10	15	20	25	30	40	50	60	
To obtain BTU for other Water Temperature Drops, multiply basic BTU rating by applicable Factor.	1.25	1.15	1.08	1.00	.94	.90	.83	.76	.72	
To obtain GPM for other Water Temperature Drops, multiply basic GPM rating by applicable Factor.	5.00	2.30	1.44	1.00	.74	.59	.40	.30	.24	
To obtain Pressure Loss Feet of Water for other temperature Drops, multiply Basic loss at 20°F drop by Factor.	10.00	5.00	2.00	1.00	.60	.40	.20	.13	.07	

See page 23 for altitude and glycol correction factors.

TABLE 9 — CFM AT VARIOUS EAT

Entering Air Temperature	30°F	40°F	50°F	60°F	70°F	80°F	90°F
Conversion Factor	1.06	1.04	1.02	1.00	0.982	0.964	0.945

STANDARD EQUIPMENT OPTIONS & ACCESSORY EQUIPMENT

BASIC UNIT

16-gauge front panel, 18-gauge ends and tops of cold rolled steel for all units; the internal casing shall be furnished of galvanized steel; steam or hot water coil with 1-1/4" copper tube stub ends, 115 volt PSC motor of (1/10 or 1/15 HP); centrifugal forward curved double width fan wheel with galvanized fan housing; variable speed fan control located right hand (shipped loose on ceiling units); permanent aluminum filter, cleanable; left hand piping (field reversible, fan switch must also be reversed); stamped louvered inlet and outlet as shown in catalog; baked powder eggshell finish. Air flow arrangements do not affect price.

ACCESS DOORS - F, FI, FS, FSI, W, WI units, 2 top access doors; RW, RWI units, 2 front panel access doors. Model C and RC provide no access doors in hinged front panel.

FACTORY ASSEMBLED OPTIONS

OPTION 10 - Limited Access Fasteners - for front panel for all models. Special tool required for opening panel.

OPTION 11 - Limited Access Fasteners - for access doors. Not applicable to models C and RC. Special tool required for opening doors.

OPTION 12 - Aluminum Grille - in place of standard louver. Heavy duty bar grille has clear anodized finish and can be painted to match decorator colors if so specified.

OPTION 13 - Decorator Color - may be selected from color selector. A prime coat of neutral eggshell baked powder enamel is standard unless otherwise specified. This may be the final finish or it may be painted in the field if necessary.

OPTION 17 - Louvered Inlet Grille - available on models F or FS. Recommended for aesthetics when option 18,19, 118 or 119 is ordered (standard with models FI and FSI).

OPTION 18 - 25% Manual Outside Air Damper - outside air intake can be adjusted from 0 to 25%. Control is by manual quadrant. See Option 17. Available for field installation - see option 118. Must be ordered with models F-1010, FS-1015, F-1030 and FS-1035.

OPTION 19 - 25% Motorized Outside Air Damper - opens outside air intake to 25% when blower starts. Closes when blower stops. Override switch is provided to prevent damper operation when desired. See Option 17. Available for field installation - see option 119. Must be ordered with models F-1010, FS-1015, F-1030 and FS-1035.

OPTION 20 - High Static Motor - 1/11 HP -1550 RPM 115/1/60 1.2 amp PSC motor. Will maintain standard air flow against 0.4" WC max. See option 114.

OPTION 21 - Plug In Motor - heavy duty grounded plug in cord set for connection to convenience outlet. Not CSA approved.

OPTION 22 - Motor Starter - manual reset toggle switch with thermal overload. Unit must be turned off and then back on if overload trips. Not available with ECM.

OPTION 23 - Service Switch DPST - provides a handy means of disconnecting both hot and neutral power lines.

OPTION 24F - Return Air Temperature Control - provides return air thermostat to cycle unit blower(s) if return temperature is too low. Blower shuts off when thermostat is satisfied (adjustable from 55-175°F). For Celsius order OPTION 24C. Not recommended for ceiling or inverted flow units.

OPTION 26 - Right hand coil connection.

OPTION 28 - 1/2" Neoprene Faced Fiberglass Insulation All External Panels of Cabinet.

OPTION 29 - High Capacity Coil - two row high capacity coil for hot water only.

OPTION 30 - 1/2" Foil Faced Fiberglass Insulation - Front Panel (Coil Area Only).

OPTION 31 - 1/2" Foil Faced Fiberglass Insulation - All External Panels of Cabinet.

OPTION 32 - 3/8" Closed Cell Insulation - Front Panel (Coil Area Only).

OPTION 33 - 3/8" Closed Cell Insulation - All External Panels of Cabinet.

OPTION 40 - 24VAC 40 VA Transformer can be used for powering 24VAC devices like control boards, low voltage thermostats, relays, valves, etc.

OPTION 50 - ECM Motor with Control Board, 3 Speed Switch and Service Switch.

OPTION 51 - High Static ECM Motor with Control Board, 3 Speed Switch and Service Switch.

OPTION 99 - 14-gauge Front Panel.

FIELD INSTALLED ACCESSORIES

OPTION 113 - Touch Up Paint - Aerosol Spray Can (12 oz).

OPTION 114 - Duct Collar Kit - provides flange pieces and hardware for field installation of inlet or outlet duct collar over existing louver area. Louvered area to be removed prior to installation. Standard on RC-1210 inlet and outlet. Standard on C-1150 and RC-1190 outlet.

OPTION 116 - Leveling Legs - for floor mounted units - 2 per pedestal, 4 per unit.

OPTION 118 - 25% Manual Outside Air Damper kit for field installation. See option 18 for description.

OPTION 119 - 25% Motorized Outside Air Damper kit for field installation. See option 19 for description.

OPTION 125 - Aquastat Control - strap-on aquastat keeps blower(s) off until return water temperature reaches setpoint (adjustable from 100-240°F).

OPTION 126A & B - Wall Seal - for recessed installation, either fully or 2-1/4" partial. Models where full recess would interfere with inlet and/or outlet airflow may be recessed 2-1/4". See schedule below. NOTE: Wall Seal kits are furnished with models RC, RW and RWI. Kits must be ordered under this option number for all other models.

TABLE 10 - WALL SEAL SCHEDULE* (see page 20)

MODEL	RECESSED	2 1/4" PARTIAL RECESS	OPTION 126
F	F-1020, F-1030	F-1000, F-1010	A
FI	FI-1050	FI-1040	A
W, RW	RW-1120	W-1060, W-1070	B
WI, RWI	RWI-1130	WI-1090, WI-1100	B
C, RC	C-1170, RC-1200	C-1140, C-1150 C-1160, C-1180 RC-1190, RC-1210	B

*Not Applicable to models FS or FSI.

OPTION 127A - Line Voltage Room (Wall) Thermostat - Heating only with combined temperature select/off dial. Range 50-90°F. Rated 22.0 amps @ 120 VA.

OPTION 129 - Extra Filter - provides an additional filter (permanent aluminum mesh). One required per unit, all sizes.

OPTION 140 - 24VAC 40 VA Transformer can be used for powering 24VAC devices like control boards, low voltage thermostats, relays, valves, etc.

DIMENSIONAL DATA

Floor Mounted Units Models F and FI

Piping from bottom or rear.

FILTER IDENTIFICATION AND DATA		
SIZE	PART NO.	FILTER SIZE
02	PC1297-2	15/32" x 8 11/16" x 19 3/4"
03	PC1297-3	15/32" x 8 11/16" x 27 3/4"
04	PC1297-4	15/32" x 8 11/16" x 31 3/4"
06	PC1297-6	15/32" x 8 11/16" x 43 3/4"
08	PC1297-8	15/32" x 8 11/16" x 45 3/4"
10	PC1297-10	15/32" x 8 11/16" x 50 3/4"
12	PC1297-12	15/32" x 8 11/16" x 57 3/4"
14	PC1297-14	15/32" x 8 11/16" x 69 3/4"

SIZE	DIM "A"	DIM "L"
02	6 1/8"	35"
03	6 1/8"	43"
04	6 1/8"	47"
06	10 5/8"	59"
08	10 5/8"	61"
10	10 5/8"	66"
12	16 5/8"	73"
14	16 5/8"	85"

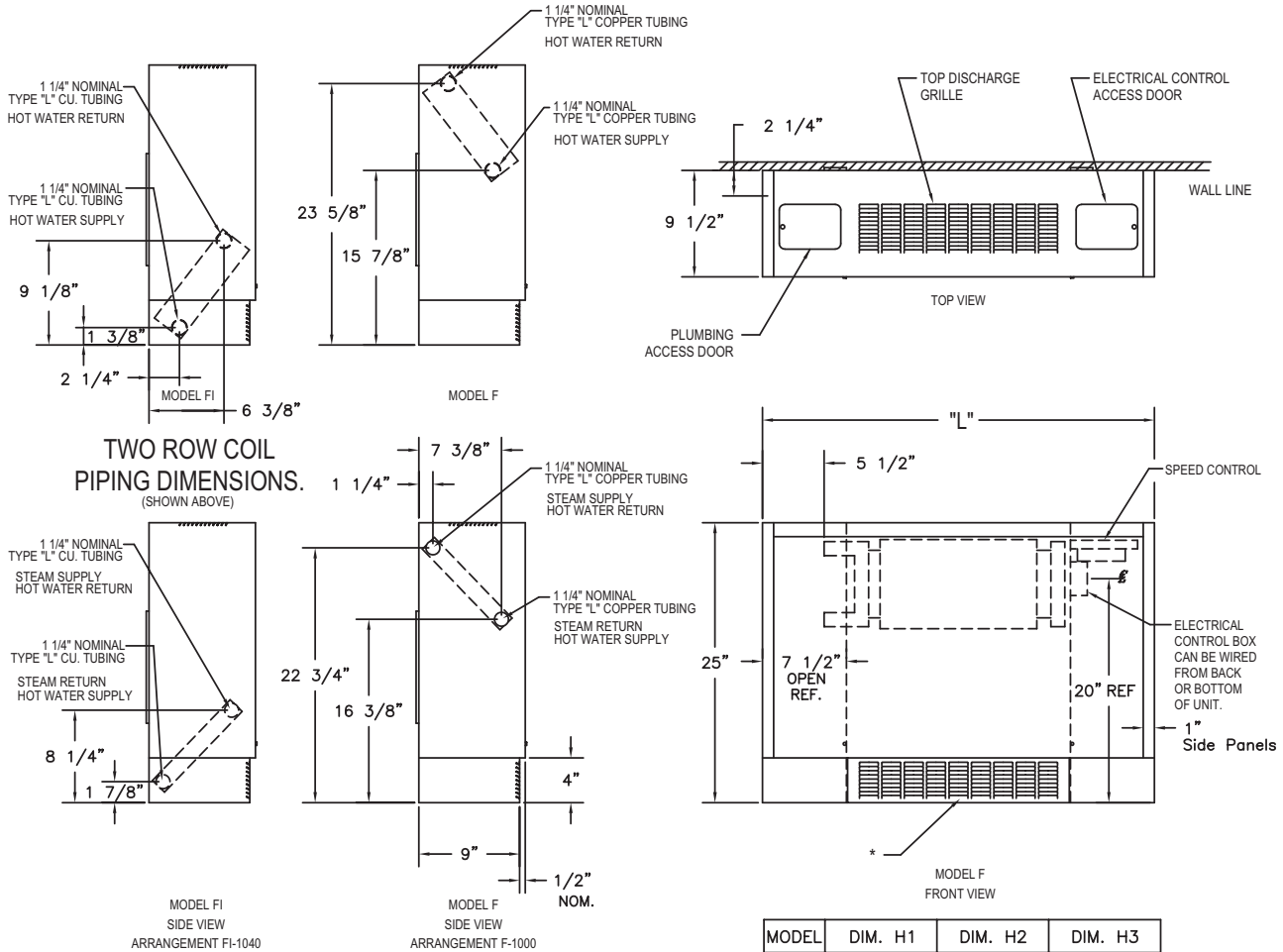

MODEL	DIM. H1	DIM. H2	DIM. H3
F	9 1/8"	12 1/8"	15 1/8"
FI	9 1/2"	12 1/2"	15 1/2"

STANDARD ONE ROW COIL PIPING DIMENSIONS. (SHOWN ABOVE)

THIS DATA SHEET SHOWS FLOOR MOUNTED UNITS
MODELS "F AND FI" - WITH TOP DISCHARGE.

PIPING AND MOUNTING CONNECTIONS SHOWN ARE TYPICAL
FOR ALL AIR FLOW ARRANGEMENTS.

SEE PAGE 6 for other air flow arrangements.

Access doors located on front of units with front discharge.

* LOUVERED INLET GRILLE IS
STANDARD ON "FI" MODELS
OPTIONAL ON "F" MODELS
SEE OPTION 17

MAXIMUM RECESS DEPTH
MODELS F1000, F1010, F1040 ONLY.

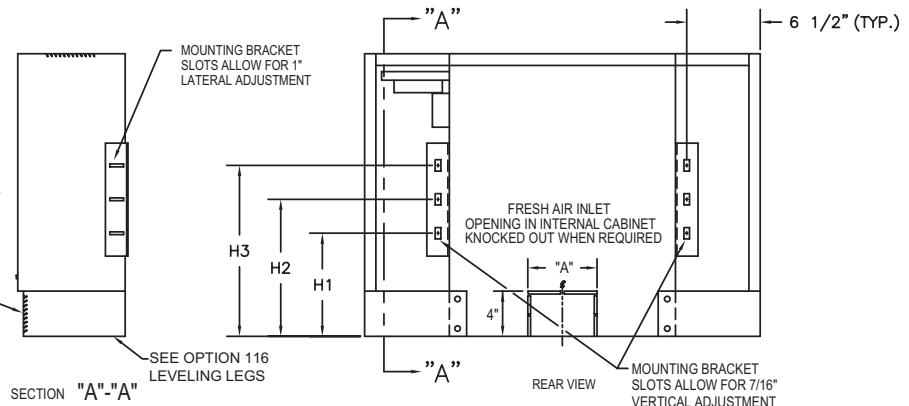

DIMENSIONAL DATA

Floor Mounted Units Models FS and FSI

Piping from bottom or rear.

SIZE	PART NO.	FILTER SIZE
02	PC1297-2	15/32" x 8 11/16" x 19 3/4"
03	PC1297-3	15/32" x 8 11/16" x 27 3/4"
04	PC1297-4	15/32" x 8 11/16" x 31 3/4"
06	PC1297-6	15/32" x 8 11/16" x 43 3/4"
08	PC1297-8	15/32" x 8 11/16" x 45 3/4"
10	PC1297-10	15/32" x 8 11/16" x 50 3/4"
12	PC1297-12	15/32" x 8 11/16" x 57 3/4"
14	PC1297-14	15/32" x 8 11/16" x 69 3/4"

SIZE	DIM "A"	DIM "L"
02	6 1/8"	35"
03	6 1/8"	43"
04	6 1/8"	47"
06	10 5/8"	59"
08	10 5/8"	61"
10	10 5/8"	66"
12	16 5/8"	73"
14	16 5/8"	85"

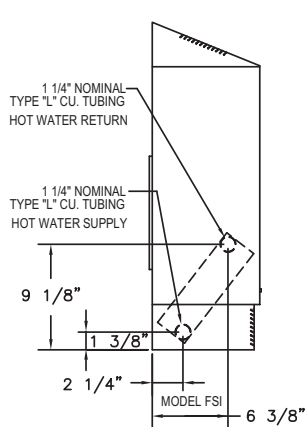

TWO ROW COIL PIPING DIMENSIONS.

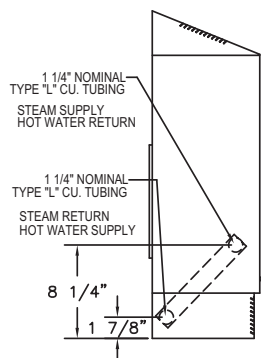

MODEL FSI
SIDE VIEW
ARRANGEMENT FSI-1045

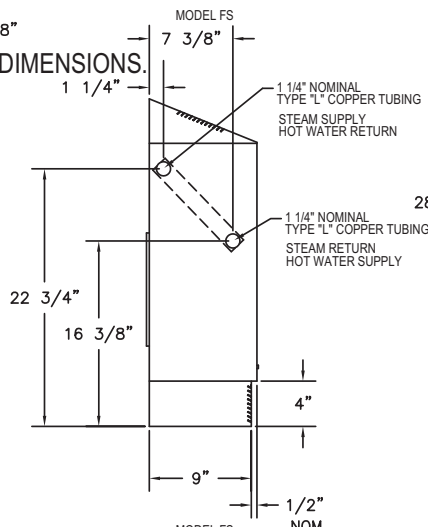
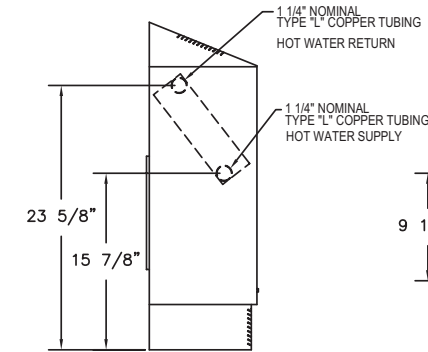

MODEL FS
SIDE VIEW
ARRANGEMENT FS-1005

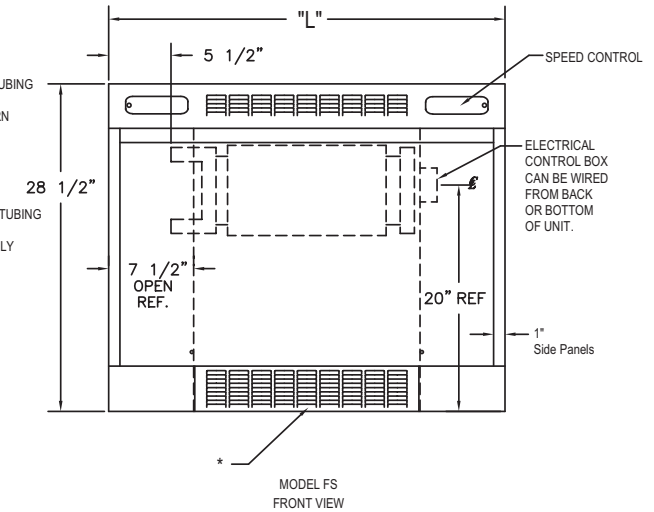
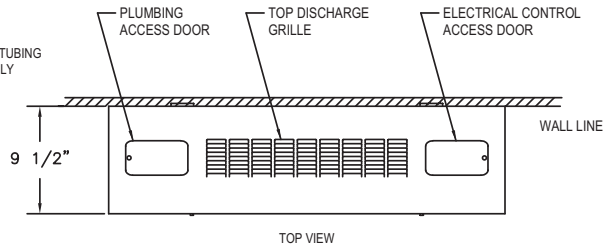

STANDARD ONE ROW COIL
PIPING DIMENSIONS.

MODEL	DIM. H1	DIM. H2	DIM. H3
FS	9 1/8"	12 1/8"	15 1/8"
FSI	9 1/2"	12 1/2"	15 1/2"

THIS DATA SHEET SHOWS FLOOR MOUNTED UNITS
MODELS "FS AND FSI" - WITH TOP DISCHARGE.

PIPING AND MOUNTING CONNECTIONS SHOWN ARE TYPICAL
FOR ALL AIR FLOW ARRANGEMENTS.

SEE PAGE 6 for other air flow arrangements.

Access doors located on front of units with front discharge.

* LOUVERED INLET GRILLE IS
STANDARD ON "FSI" MODELS
OPTIONAL ON "FS" MODELS
SEE OPTION 17

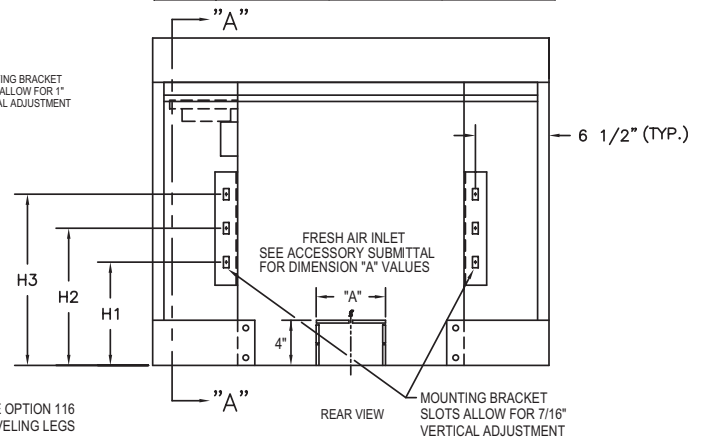
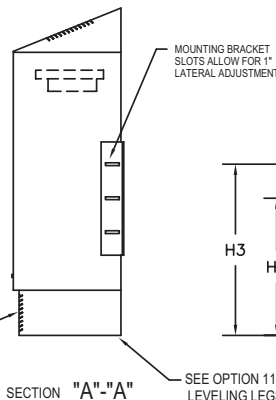

DIMENSIONAL DATA

Wall Mounted Units Models W and WI

Piping from rear only.

FILTER IDENTIFICATION AND DATA		
SIZE	PART NO.	FILTER SIZE
02	PC1297-2	15/32" x 8 11/16" x 19 3/4"
03	PC1297-3	15/32" x 8 11/16" x 27 3/4"
04	PC1297-4	15/32" x 8 11/16" x 31 3/4"
06	PC1297-6	15/32" x 8 11/16" x 43 3/4"
08	PC1297-8	15/32" x 8 11/16" x 45 3/4"
10	PC1297-10	15/32" x 8 11/16" x 50 3/4"
12	PC1297-12	15/32" x 8 11/16" x 57 3/4"
14	PC1297-14	15/32" x 8 11/16" x 69 3/4"

SIZE	DIM "L"
02	35"
03	43"
04	47"
06	59"
08	61"
10	66"
12	73"
14	85"

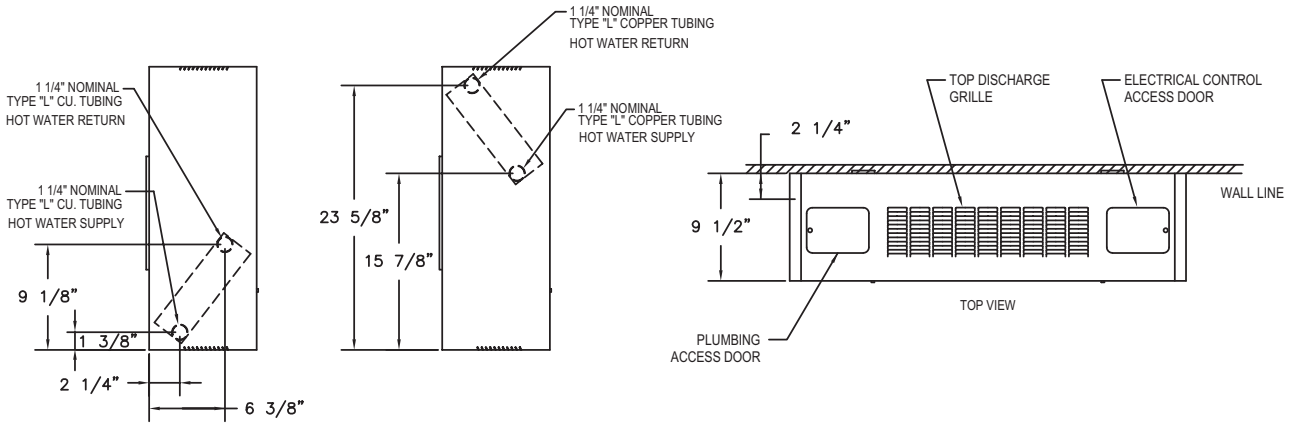

TWO ROW COIL
PIPING DIMENSIONS.
(SHOWN ABOVE)

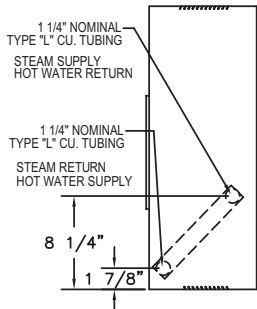

MODEL WI
SIDE VIEW
ARRANGEMENT WI-1090

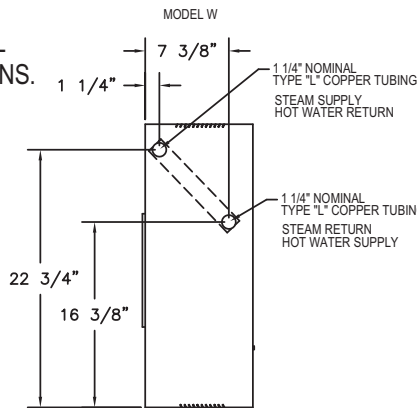

MODEL W
SIDE VIEW
ARRANGEMENT W-1060

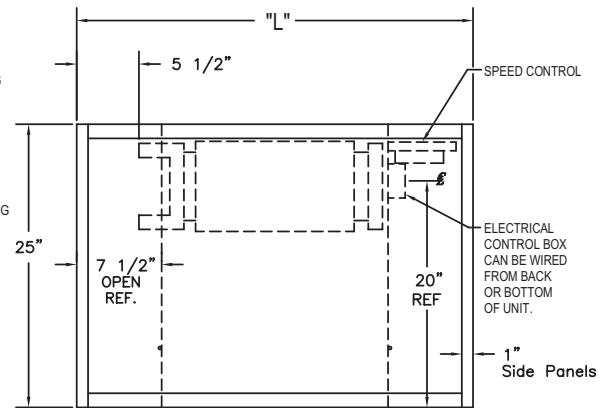

MODEL W
FRONT VIEW

STANDARD ONE ROW COIL
PIPING DIMENSIONS.
(SHOWN ABOVE)

MODEL	DIM. H1	DIM. H2	DIM. H3
W	9 1/8"	12 1/8"	15 1/8"
WI	9 1/2"	12 1/2"	15 1/2"

THIS DATA SHEET SHOWS WALL MOUNTED UNITS
MODELS "W AND WI" - WITH TOP DISCHARGE.

PIPING AND MOUNTING CONNECTIONS SHOWN ARE TYPICAL
FOR ALL AIR FLOW ARRANGEMENTS.

SEE PAGE 6 for other air flow arrangements.

Access doors located on front of units with front discharge.

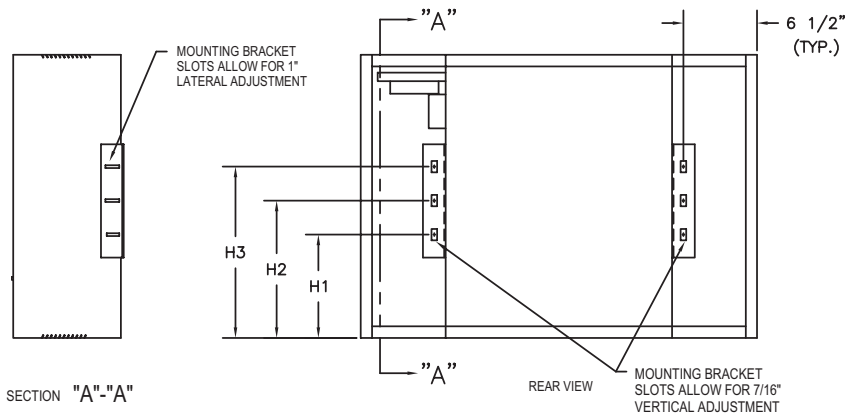

SECTION "A"- "A"

◊ MAXIMUM RECESS DEPTH
MODELS W1060, W1070, W11090, W11100 ONLY.

DIMENSIONAL DATA

Recessed Wall Mounted Units Models RW and RWI

Piping from rear only.

FILTER IDENTIFICATION AND DATA		
SIZE	PART NO.	FILTER SIZE
02	PC1297-2	15/32" x 8 11/16" x 19 3/4"
03	PC1297-3	15/32" x 8 11/16" x 27 3/4"
04	PC1297-4	15/32" x 8 11/16" x 31 3/4"
06	PC1297-6	15/32" x 8 11/16" x 43 3/4"
08	PC1297-8	15/32" x 8 11/16" x 45 3/4"
10	PC1297-10	15/32" x 8 11/16" x 50 3/4"
12	PC1297-12	15/32" x 8 11/16" x 57 3/4"
14	PC1297-14	15/32" x 8 11/16" x 69 3/4"

SIZE	DIM "L"
02	35"
03	43"
04	47"
06	59"
08	61"
10	66"
12	73"
14	85"

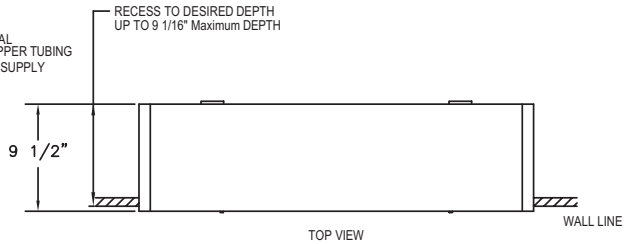
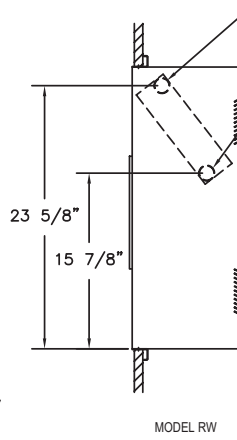
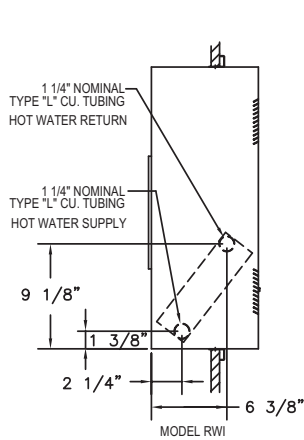

TWO ROW COIL PIPING DIMENSIONS.

(SHOWN ABOVE)

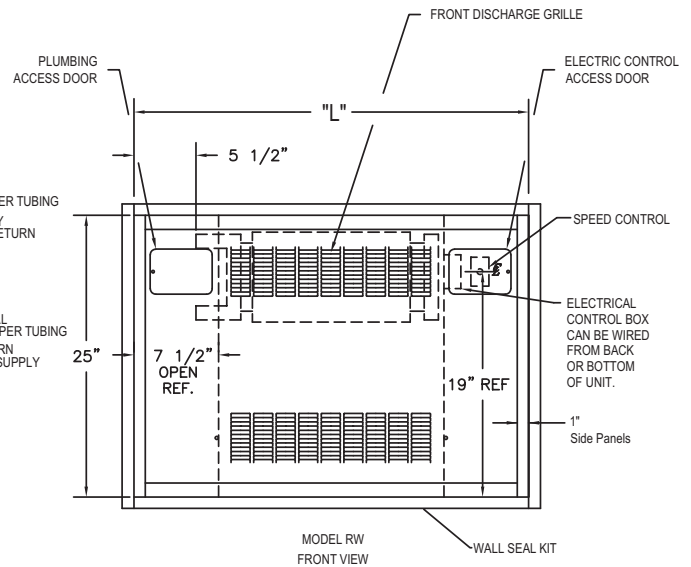
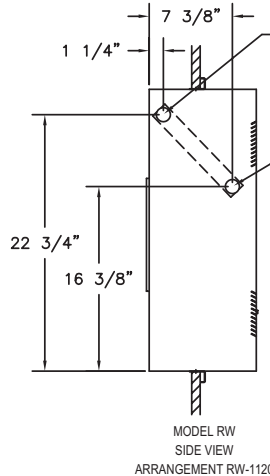
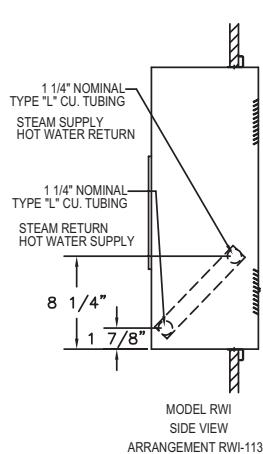

MODEL	DIM. H1	DIM. H2	DIM. H3
RW	9 1/8"	12 1/8"	15 1/8"
RWI	9 1/2"	12 1/2"	15 1/2"

STANDARD ONE ROW COIL PIPING DIMENSIONS.

(SHOWN ABOVE)

THIS DATA SHEET SHOWS RECESSED WALL MOUNTED UNITS MODELS "RW AND RWI" - WITH FRONT DISCHARGE.

PIPING AND MOUNTING CONNECTIONS SHOWN ARE TYPICAL FOR ALL AIR FLOW ARRANGEMENTS.

SEE PAGE 6 for other air flow arrangements.

Access doors located on front of units with front discharge.

SEE PAGE 20 for Wall Seal Kit.

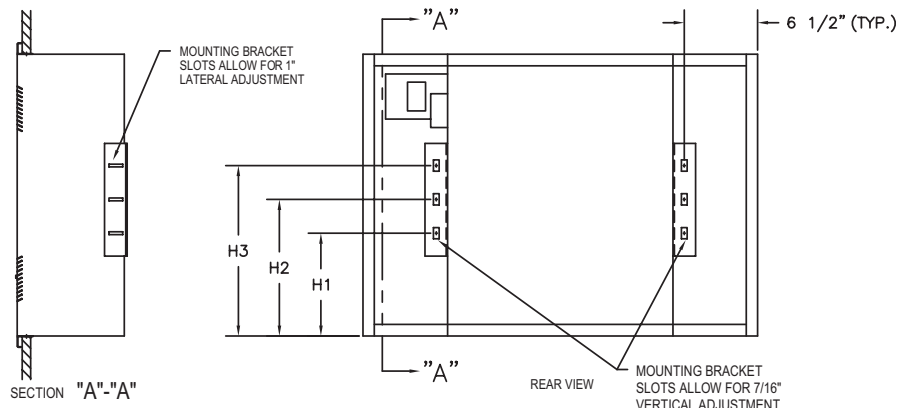

DIMENSIONAL DATA

Ceiling Mounted Unit (Non Recessed Only) Model C

Piping from rear only.

FILTER IDENTIFICATION AND DATA		
SIZE	PART NO.	FILTER SIZE
02	PC1297-2	15/32" x 8 11/16" x 19 3/4"
03	PC1297-3	15/32" x 8 11/16" x 27 3/4"
04	PC1297-4	15/32" x 8 11/16" x 31 3/4"
06	PC1297-6	15/32" x 8 11/16" x 43 3/4"
08	PC1297-8	15/32" x 8 11/16" x 45 3/4"
10	PC1297-10	15/32" x 8 11/16" x 50 3/4"
12	PC1297-12	15/32" x 8 11/16" x 57 3/4"
14	PC1297-14	15/32" x 8 11/16" x 69 3/4"

SIZE	DIM "L"	DIM "W"
02	35"	18 1/8"
03	43"	26 1/8"
04	47"	30 1/8"
06	59"	42 1/8"
08	61"	44 1/8"
10	66"	49 1/8"
12	73"	56 1/8"
14	85"	68 1/8"

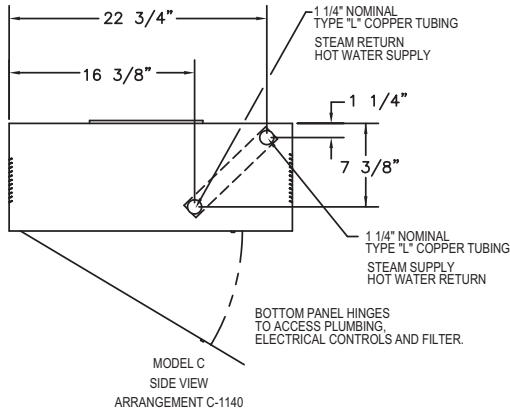

MODEL C
SIDE VIEW
ARRANGEMENT C-1140

STANDARD ONE ROW COIL
PIPING DIMENSIONS.
(SHOWN ABOVE)

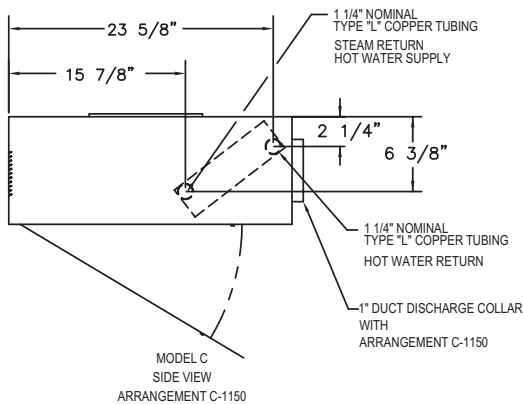

MODEL C
SIDE VIEW
ARRANGEMENT C-1150

TWO ROW COIL PIPING DIMENSIONS
(SHOWN ABOVE)

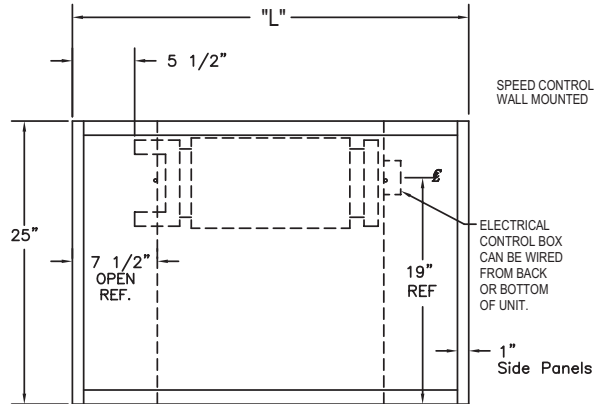
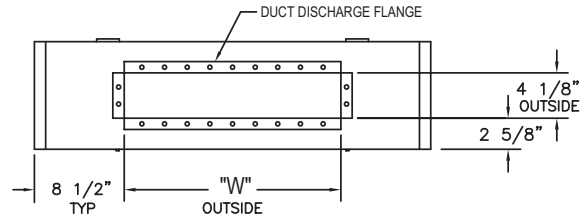
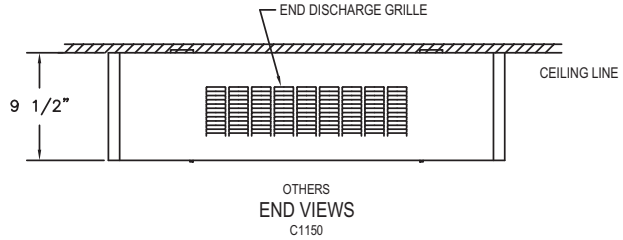

MODEL C
FRONT/BOTTOM VIEW

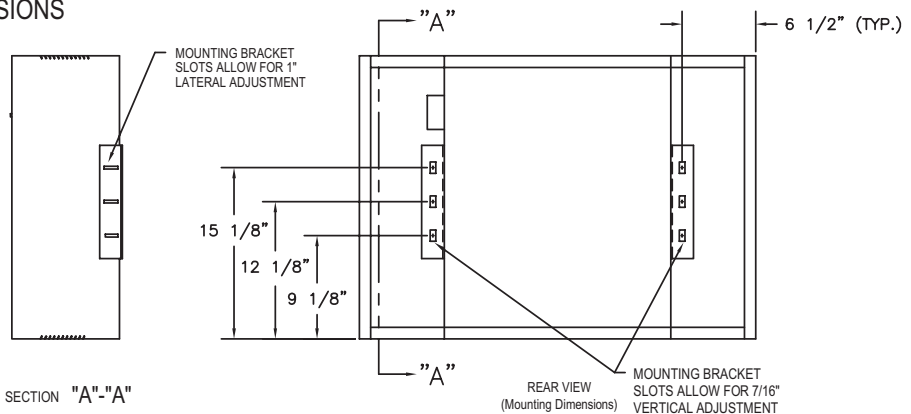

SECTION "A"- "A"

REAR VIEW
(Mounting Dimensions)

THIS DATA SHEET SHOWS CEILING MOUNTED UNITS
(Non Recessed ONLY) MODELS "C".

PIPING AND MOUNTING CONNECTIONS SHOWN ARE TYPICAL
FOR ALL AIR FLOW ARRANGEMENTS.
SEE PAGE 6 for other air flow arrangements.

◇ MAXIMUM RECESS DEPTH
MODELS C1140, C1150, C1160, C1180 ONLY.

DIMENSIONAL DATA

Recessed Ceiling Unit Model RC

Piping from rear only.

FILTER IDENTIFICATION AND DATA		
SIZE	PART NO.	FILTER SIZE
02	PC1297-2	15/32" x 8 11/16" x 19 3/4"
03	PC1297-3	15/32" x 8 11/16" x 27 3/4"
04	PC1297-4	15/32" x 8 11/16" x 31 3/4"
06	PC1297-6	15/32" x 8 11/16" x 43 3/4"
08	PC1297-8	15/32" x 8 11/16" x 45 3/4"
10	PC1297-10	15/32" x 8 11/16" x 50 3/4"
12	PC1297-12	15/32" x 8 11/16" x 57 3/4"
14	PC1297-14	15/32" x 8 11/16" x 69 3/4"

SIZE	DIM "L"	DIM "W"
02	35"	18 1/8"
03	43"	26 1/8"
04	47"	30 1/8"
06	59"	42 1/8"
08	61"	44 1/8"
10	66"	49 1/8"
12	73"	56 1/8"
14	85"	68 1/8"

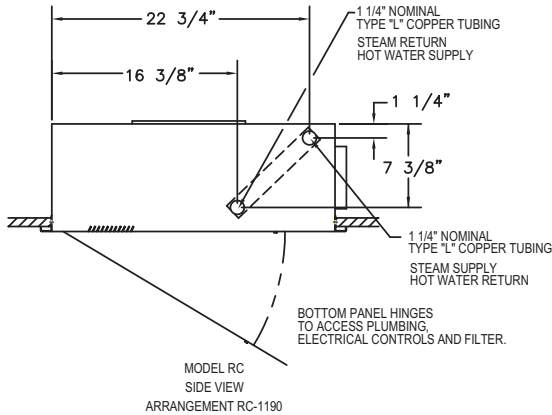

STANDARD ONE ROW COIL
PIPING DIMENSIONS.
(SHOWN ABOVE)

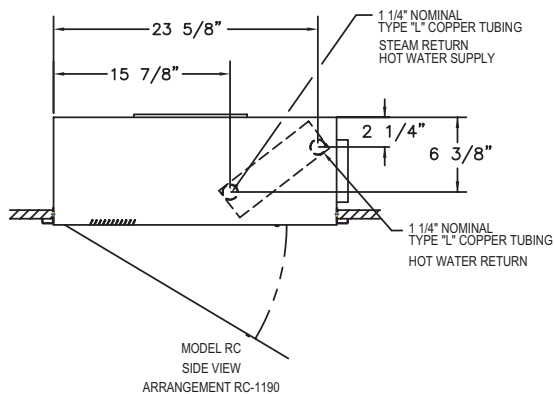
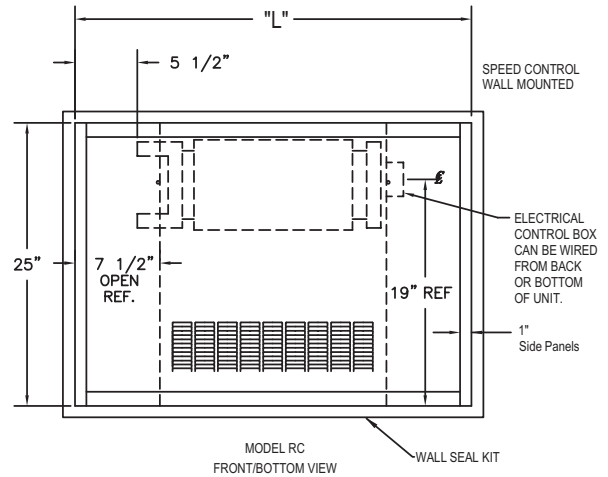
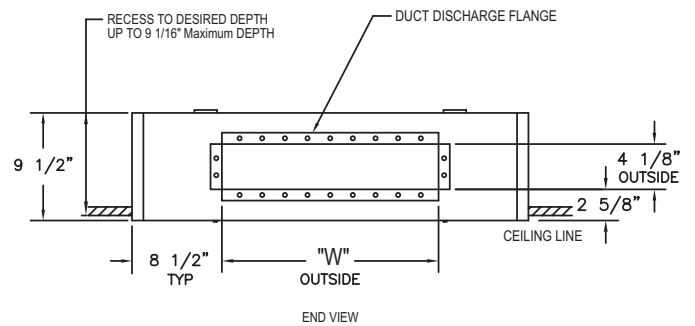

TWO ROW COIL PIPING DIMENSIONS
(SHOWN ABOVE)

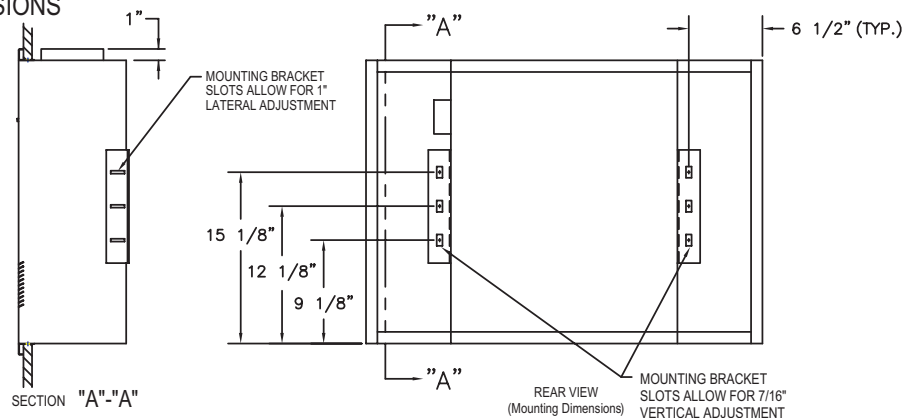

THIS DATA SHEET SHOWS RECESSED CEILING MOUNTED UNITS MODELS "RC".

PIPING AND MOUNTING CONNECTIONS SHOWN ARE TYPICAL FOR ALL AIR FLOW ARRANGEMENTS.

SEE PAGE 6 for other air flow arrangements.

SEE PAGE 20 for Wall Seal Kit.

DIMENSIONAL DATA

ACCESSORIES

WALL SEAL

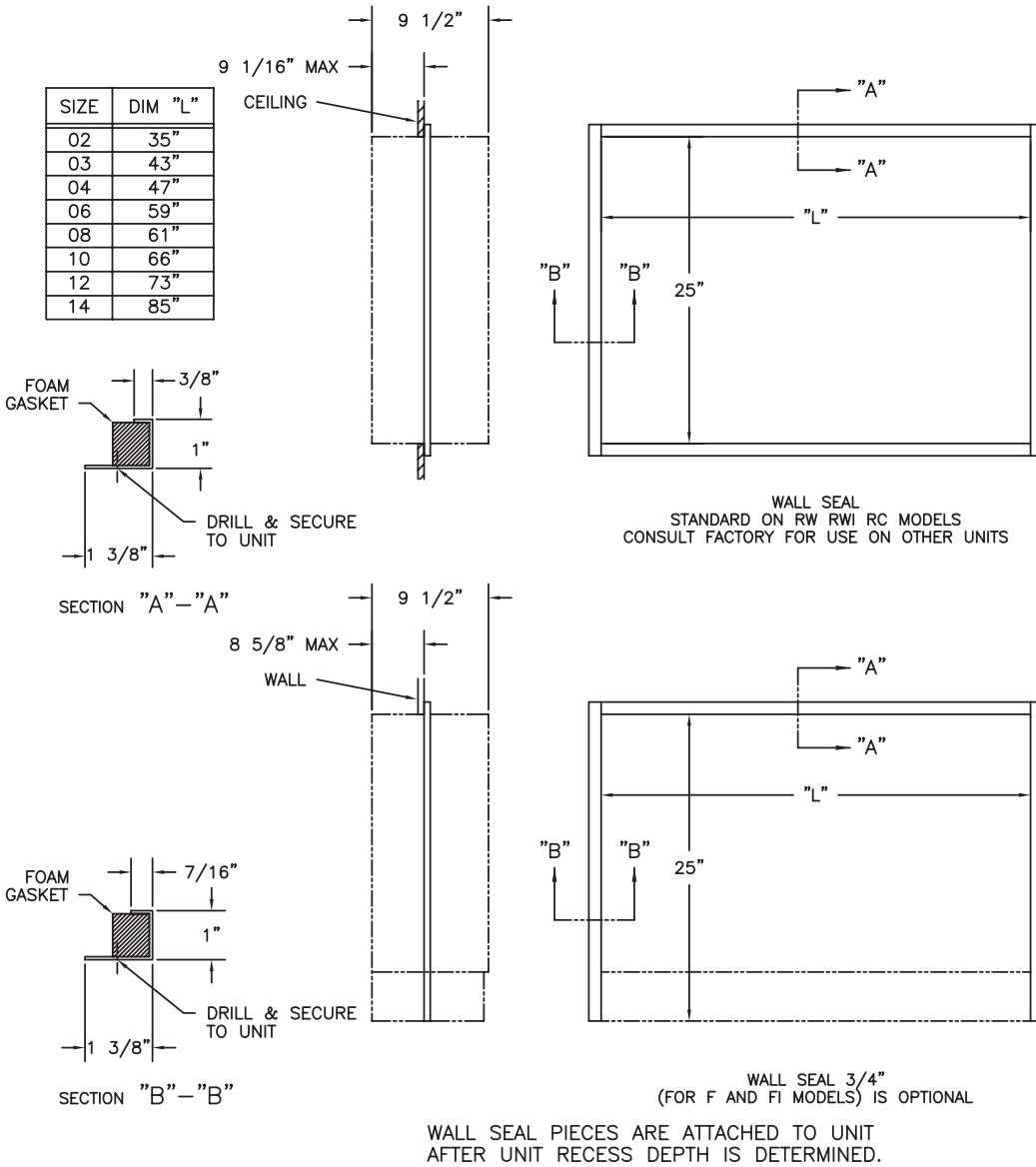

CAT00206A

DIMENSIONAL DATA

ACCESSORIES

DUCT COLLAR OUTLET AND DISCHARGE

SIZE	DIM "W"
02	18 1/8"
03	26 1/8"
04	30 1/8"
06	42 1/8"
08	44 1/8"
10	49 1/8"
12	56 1/8"
14	68 1/8"

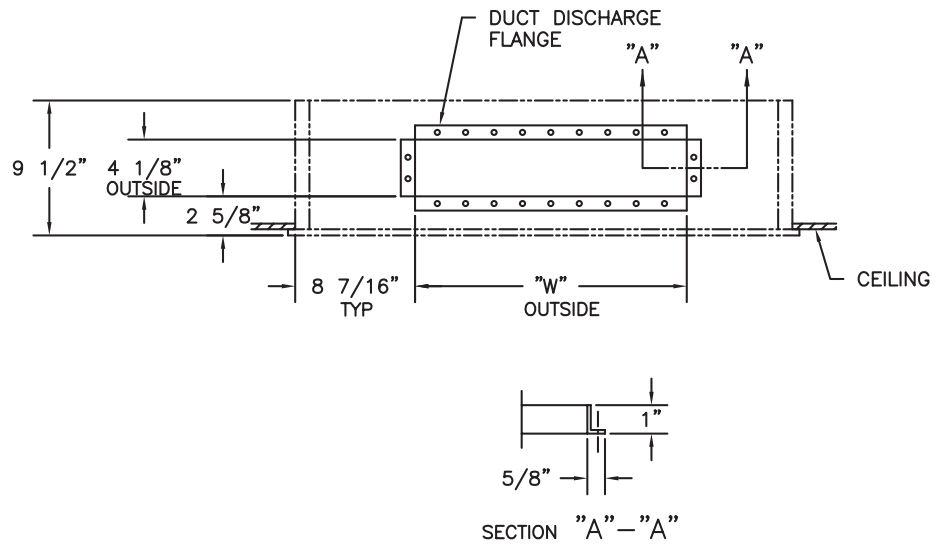

CAT00206A

FRESH AIR INLET

SIZE	DIM "A"	DIM "L"
02	6 1/8"	35"
03	6 1/8"	43"
04	6 1/8"	47"
06	10 5/8"	59"
08	10 5/8"	61"
10	10 5/8"	66"
12	16 5/8"	73"
14	16 5/8"	85"

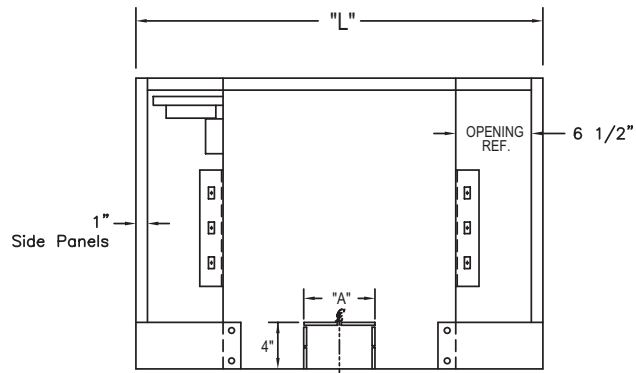

REAR VIEW
 FRESH AIR INLET
 OPENING IN INTERNAL CABINET
 KNOCKED OUT WHEN REQUIRED

Option 118 and 119

CAT00205B

OPTIONAL FEATURES



LOUVERED INLET GRILLE FOR MODELS "F" OR "FS"

The optional louvered inlet grille provides a continuous closed floor line on the Model "F". It hinders build up of dust, papers or other materials found in the normal work area. This feature is standard with Models "F" and "FS".

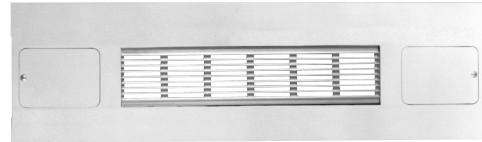

ARCHITECTURAL BAR GRILLE

Architectural clear anodized aluminum bar grille is optional on all sizes. The rugged aluminum vanes provide a strong lineal appearance preferred in professional offices and other feature areas (may be painted to match cabinet unit heater color). In place of standard louvers. Is not to be used in place of option 17.



OPTIONAL MANUAL OUTSIDE AIR DAMPER

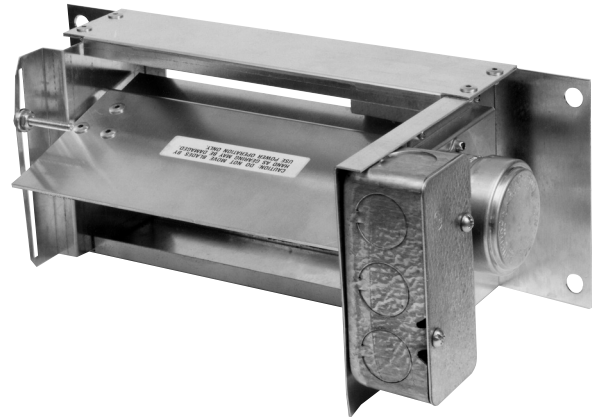

OPTIONAL MOTORIZED OUTSIDE AIR DAMPER



OPTIONAL TAMPER RESISTANT FASTENER FOR ACCESS DOOR (OPTION 11)

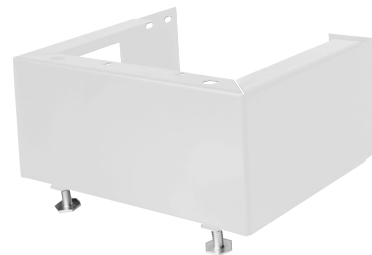

OPTIONAL LEVELING LEGS

TECHNICAL DATA

ALTITUDE FACTORS

Approximate factors for convective heat value at varying altitudes

Altitude	Ferrous Units	Copper Alum. Units
Sea Level	1.000	1.000
1,000 ft.	.984	.969
2,000 ft.	.968	.938
3,000 ft.	.952	.908
4,000 ft.	.936	.878
5,000 ft.	.920	.850
6,000 ft.	.904	.822
7,000 ft.	.889	.795
8,000 ft.	.874	.768
9,000 ft.	.859	.743
10,000 ft.	.844	.718
15,000 ft.	.771	.603
20,000 ft.	.703	.502

Note: The heat output of standard heat distributing units is not affected enough to be considered in sizing the units, when the flow rate has been increased as shown at left. If not increased, apply appropriate heat transfer correction factor indicated.

COIL CAPACITIES OF WATER

Values shown below are decimal equivalent of a U.S. gallon

Unit Size	Standard (One Row Coil)	High Capacity (Two Row Coil)
02	0.208	0.315
03	0.263	0.404
04	0.285	0.448
06	0.351	0.581
08	0.362	0.603
10	0.390	0.660
12	0.428	0.737
14	0.500	0.866

WATER IN OUNCES PER UNIT

Example: If the unit size is 04 with standard coil, then multiply .285 x 128 ounces = 36.48 ounces

†CORRECTIONS WHEN USING GLYCOL SOLUTION IN SYSTEM

		Ethylene Glycol	Propylene Glycol
1. Heat transfer @ 180°F, with no increase in flow rate	20% Solution	.946*	.982*
	30% Solution	.913*	.961*
	40% Solution	.879*	.934*
	50% Solution	.842*	.902*
2. G.P.M. req'd. @ 180°F, (no correction to pump curve)	20°Δ†	114%*	110%*
3. Pump head req'd. @ 180°F, with increase in G.P.M.		123%*	123%*
4. Freezing Point	50% by volume	-37°F	-28°F
	40%	-14°F	-13°F
	30%	+ 2°F	+ 4°F
	20%	+15°F	+17°F

*Compared To Water.

WIRING DIAGRAMS

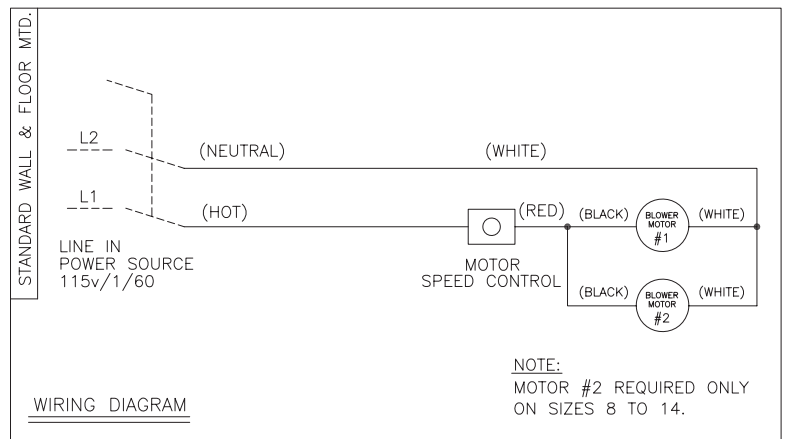

Standard Wall and Floor Units

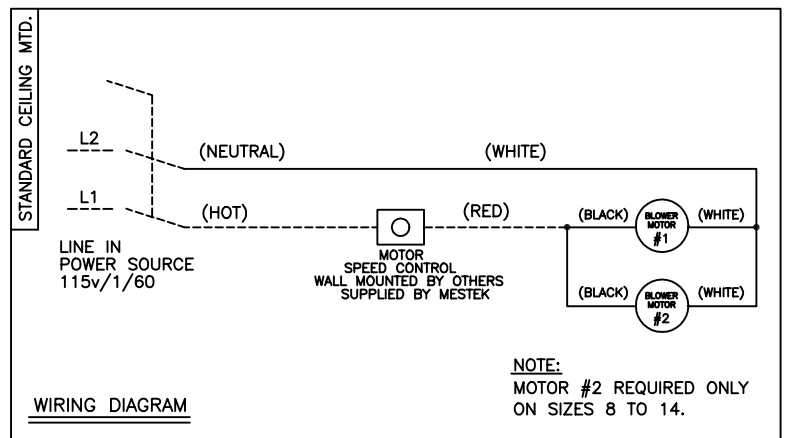

Standard Ceiling Units

SPECIFICATIONS & WARRANTY*

*STANDARD CABINET UNIT ONLY

The contractor shall furnish and install Vulcan Cabinet Unit Heaters as selected to meet or exceed job requirements. The Cabinet Unit Heaters will conform to the items listed below and be certified under CSA guidelines.

CABINETS

All cabinets will be constructed with 18-gauge cold rolled steel, side panels and top. The front panel shall be furnished in 16-gauge cold rolled steel. It will have 1/2", 1-1/2 pound insulation with one side neoprene coated in front of coil. The internal cabinet shall be furnished in 18-gauge galvanized steel. Adequate work area for installation of control valves or electrical equipment shall be provided on both sides of the internal cabinet.

The cabinet shall be provided with a neutral eggshell baked enamel prime coat as standard. (Available if specified) Powder coated baked enamel, color selected from standard.

All cabinets shall be supplied with adjustable rear mounting brackets which will provide adjustment to correct alignment of the unit at installation to non square or out of true walls, joists, studs or surfaces. Adjustable leveling legs (two each base leg) are available when specified.

RECESSED UNITS

All recessed units shall be supplied with a "Wall Seal" assembly. This assembly shall provide protection to the wall or ceiling construction material. The "Wall Seal" shall be supplied in an eggshell baked enamel prime coat as standard. (When specified) Baked enamel colors may be selected from standard.

CEILING MOUNT OR RECESSED UNITS

All "C" and "RC" units shall be supplied with a hinged front panel. The multiple hinges shall provide full swing through 90°. A safety chain shall be provided as standard to prevent the face panel from swinging fully open accidentally. This chain must be easily detached to allow full access for servicing. Speed control switch will be shipped with wiring diagram for installation where desired.

FILTERS

All filters supplied as standard shall be reusable aluminum media with a 69% arrestance level. Filters shall be slide in type which are locked into position with a cotter pin.

FANS

Fan wheels shall be centrifugal, forward curved, double width. Fan housings shall be of formed galvanized sheet metal.

COILS

STANDARD ONE ROW - The durable mechanically bonded copper/aluminum coil presents the best of today's hydronic heating technology. All element assemblies are submersion tested at factory at 250 PSI and are rated at a working pressure of 300 PSI. All units are designed so that field modifications can be made to reverse the coil position if required.
HIGH CAPACITY COIL - This is a hot water coil designed to provide increased capacity when the required load exceeds that of the standard coil for a given size. Its construction is similar to the standard coil however, there are two rows of tubes. Element assemblies are submersion tested at 250 PSI and are rated at a working pressure of 300 PSI.

MOTORS

Standard PSC motors shall have integral thermal protection and start at 78% of rated voltage. Optional PSC High Static motors will be capable of operating in high static conditions up to 4 inches of water column. All motors shall be factory run-tested and assembled in unit prior to shipping. Optional ECM and high static motors will have a solid state control board and a 3 speed switch. All motors shall be factory run-tested and assembled in unit prior to shipping.

ELECTRICAL

All primary internal wiring shall be done at the factory and every unit shall be factory tested for reliability.

FRESH AIR DAMPERS ON DESIGNATED UNITS ONLY

When desired specify either of the following:

1. Where noted 25% Manual Outside Air Dampers shall be provided. A manually operated damper quadrant shall provide from 0% to 25% outside air through the use of a single blade damper.
2. Where noted 25% Motorized Outside Air Dampers shall be provided. A synchronous motor (115/60/1) interlocked with the blower shall automatically open the outside air damper when blower starts. The single blade damper shall be adjustable from 0% to 25% outside air. When the blower stops or there is a loss of power, the damper shall return to the closed position. A damper override switch shall be provided to prevent damper operation when desired.

WARRANTY

The products in this catalog are warranted by Vulcan, to be free from defects in material and workmanship for a period of one (1) year from the date of shipment from Vulcan's plant. Vulcan's liability under this warranty is limited to replacing or repairing at our option, F.O.B. our plant any defective component or assembly returned to our factory prepaid and with proper return authorization document. All repairs or replacements are made subject to factory inspection. In the interest of product improvement, Vulcan reserves the right to make changes without notification.

Vulcan
R A D I A T O R

260 North Elm Street • Westfield, MA 01085

Tel: 413-568-9571 • Fax: 413-564-5661

www.vulcanrad.com



A MESTEK COMPANY